

*Earth Leakage Detector & Alarm*

( )

**ELD-10D**



1. PC (Remote/Local) 가 ( : ON/OFF OFF , ON/OFF .) / /
2. ( LED) , 가 (RESET) / 가
3. (REMOTE/LOCAL) PC REMOTE PC 가 ( 가 .)

**BLOCK DIAGRAM**

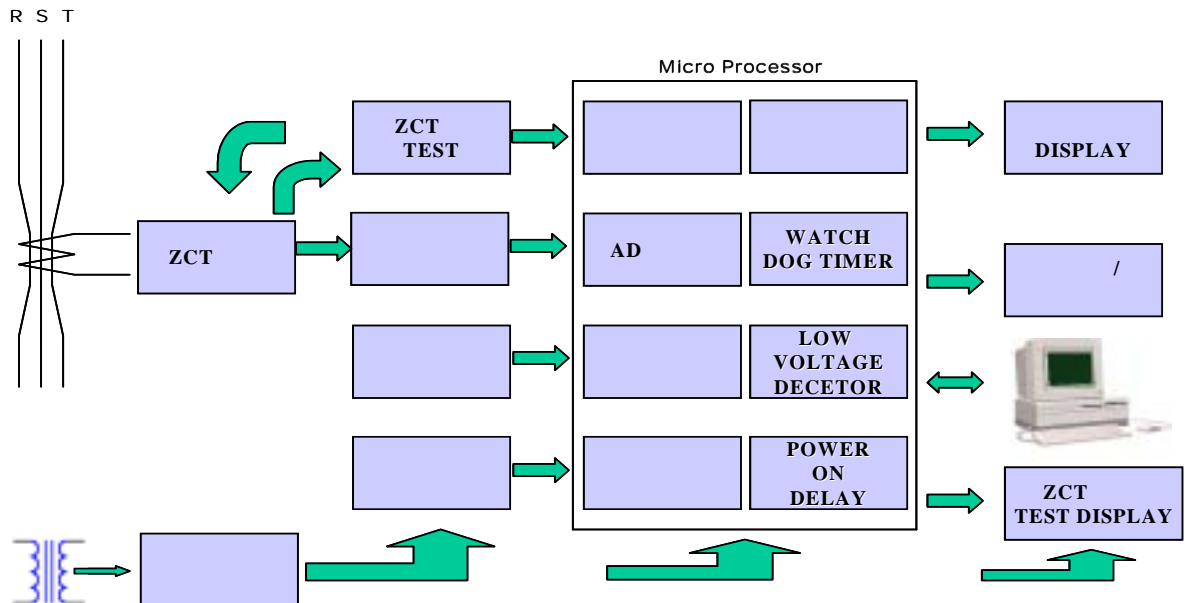

(Specifications)

Model No.	ELD-10D
	ZCT
	10Channel
	AC110/220V
	6VA
	50/60Hz
(A)	0.2, 0.5, 1.0A
	80%~120%
	AUTO/MANU
가	RS485 MODBUS Protocol Communication
LED	LED(25,50,75,100%), LED, / LED, / LED, LED
	BUZZER (85dB),
	-10 ~60
	5M
	1500V (AC60Hz, 1 )
	CASE => (Peak value : 6.0kV 1.2/50 $\mu$ s
	OFF 1mm,1000rpm, 10 4mm,1000rpm, 60
FUSE	AC250V/20A, 9.5mm, ( :BRASS BSR(1T), P.B.T)
	AC250V/0.1A
	2kg
	(H)146 X (W)146 X (D)130mm ( :Noryl SE1 GFN2)

1. ( (AC220) , ON/OFF ON  
가 AC220V . AC110V  
AC110V .)
2. ( LED) , ZCT  
LED LED가
3. 2. / , ON/OFF S/W OFF
4. ( : ZCT LED ZCT .)  
ON/OFF OFF

- 1.
2. ZCT ZCT LED가

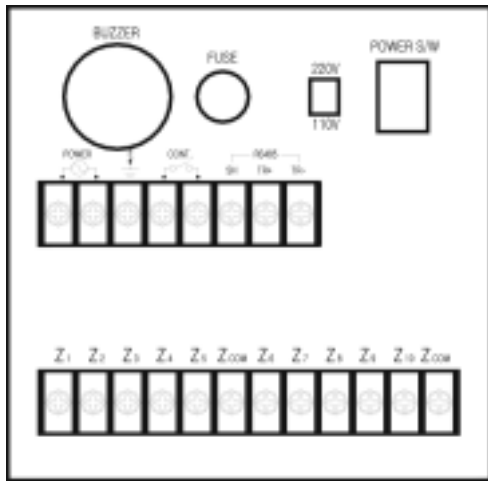

POWER S/W : ON/OFF  
 POWER : 110/220V  
 E :  
 CONT. :  
 Z1~10 : ZCT 2  
 Zcom : ZCT 2  
 TR+/TR-/SH : RS485

